

Les relais

CONTACTS TEMPORISES

Analogie: pneumatique - électrique

P.C

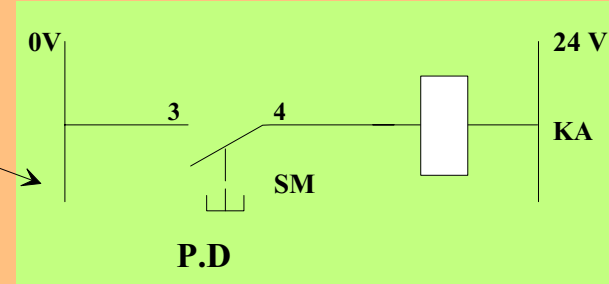
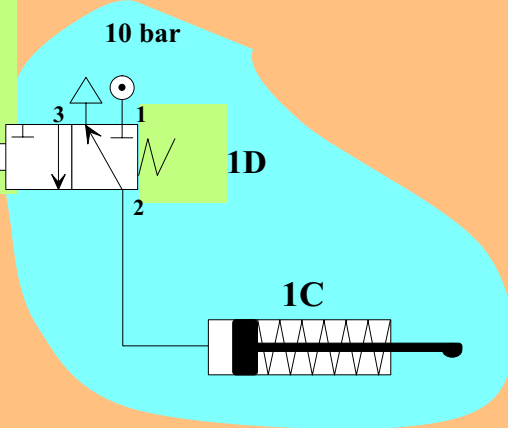
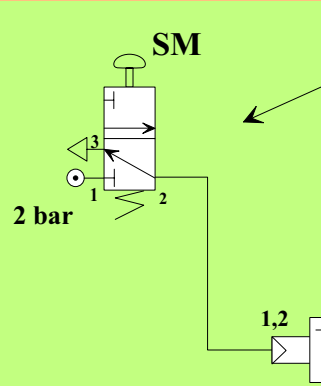

P.O

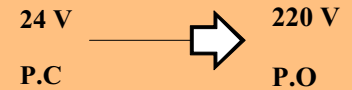
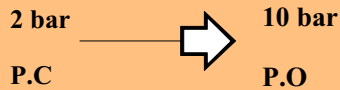
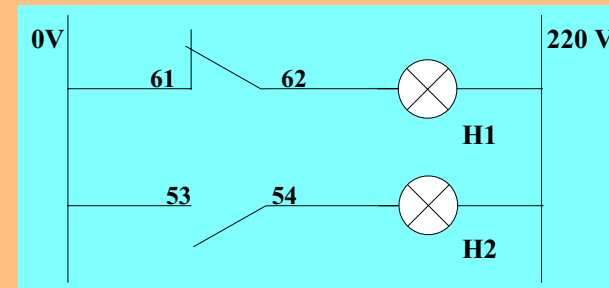

ETAT REPOS

SYMBOLISATION

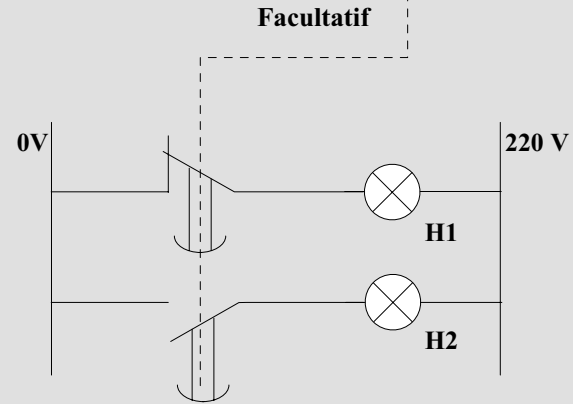
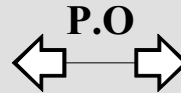
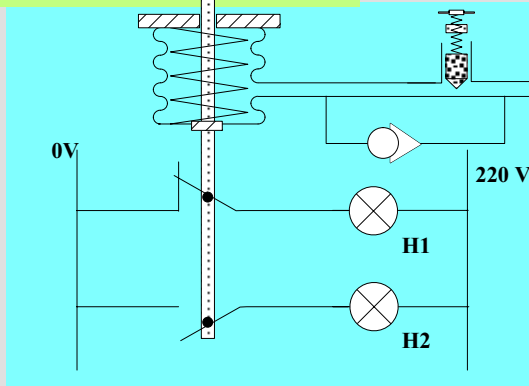
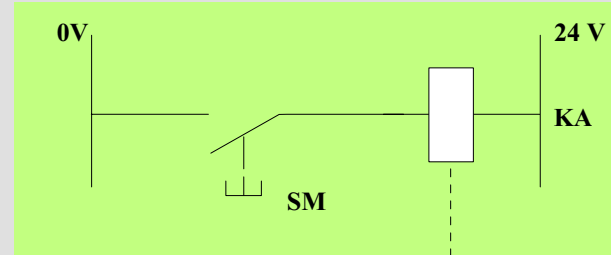
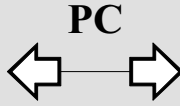
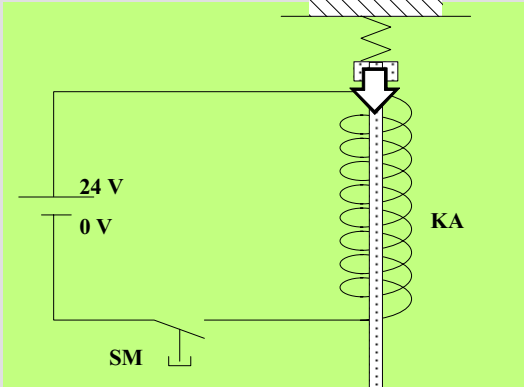

Bloc additif

Dispositif de temporisation

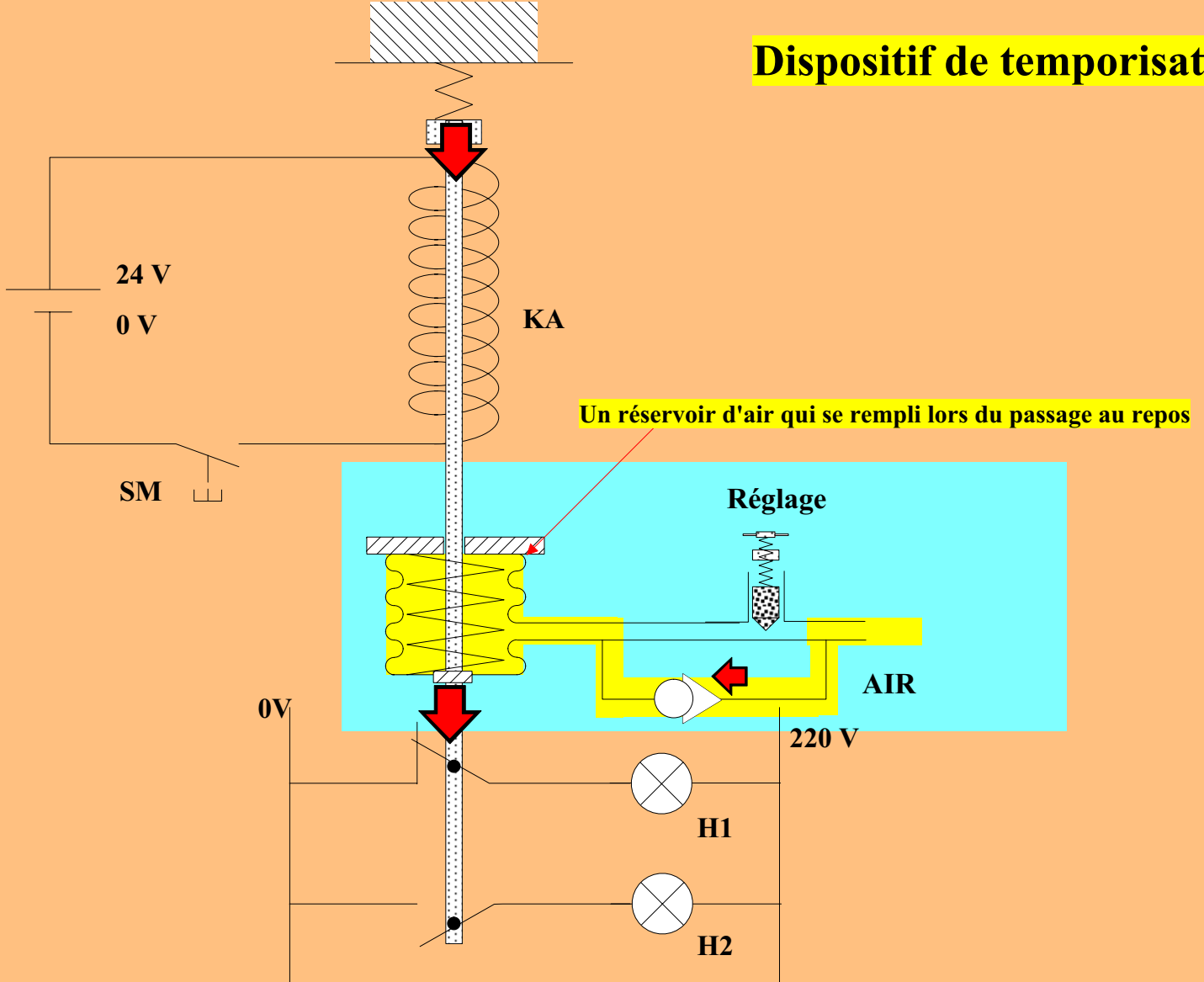

ETAT TRAVAIL

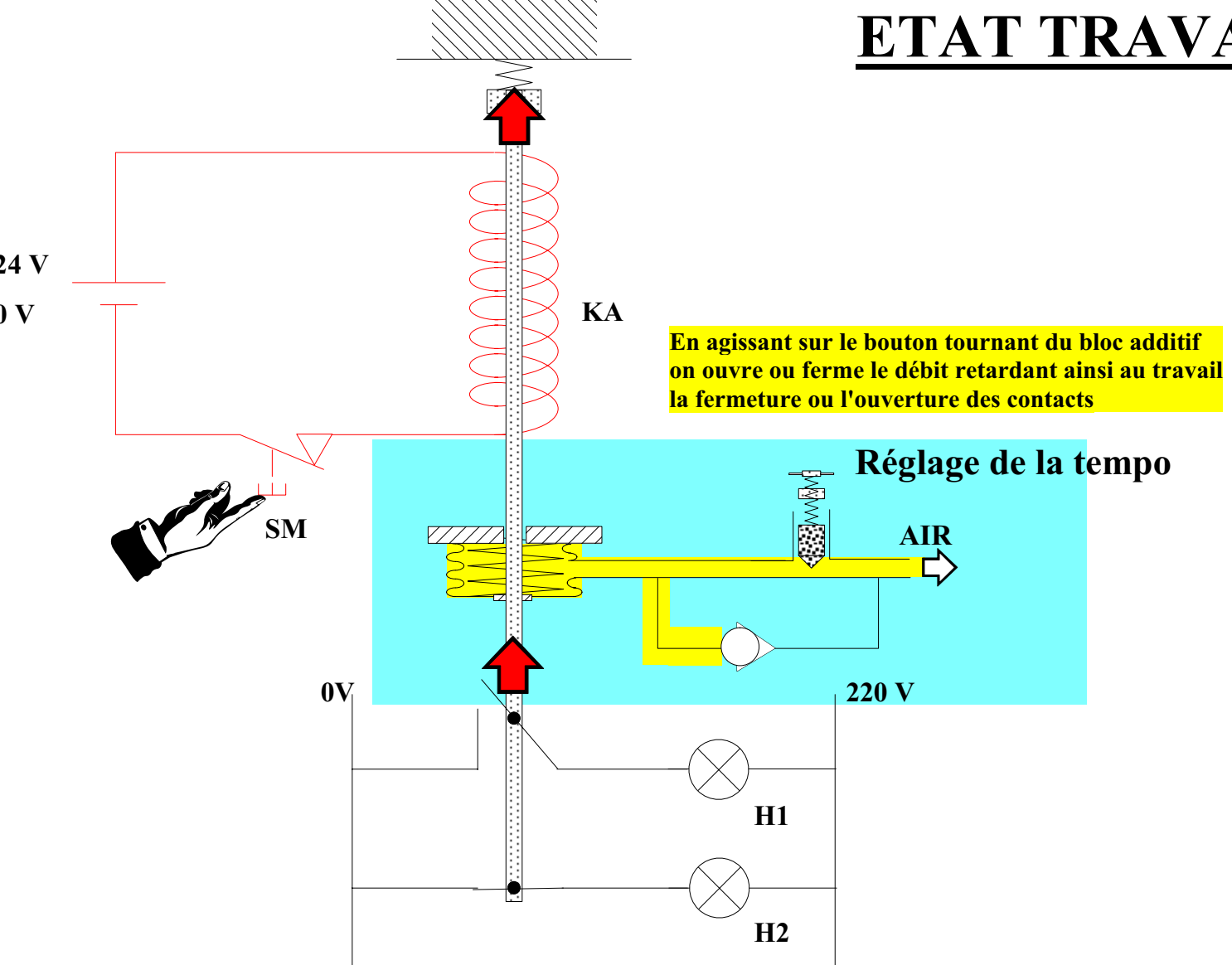

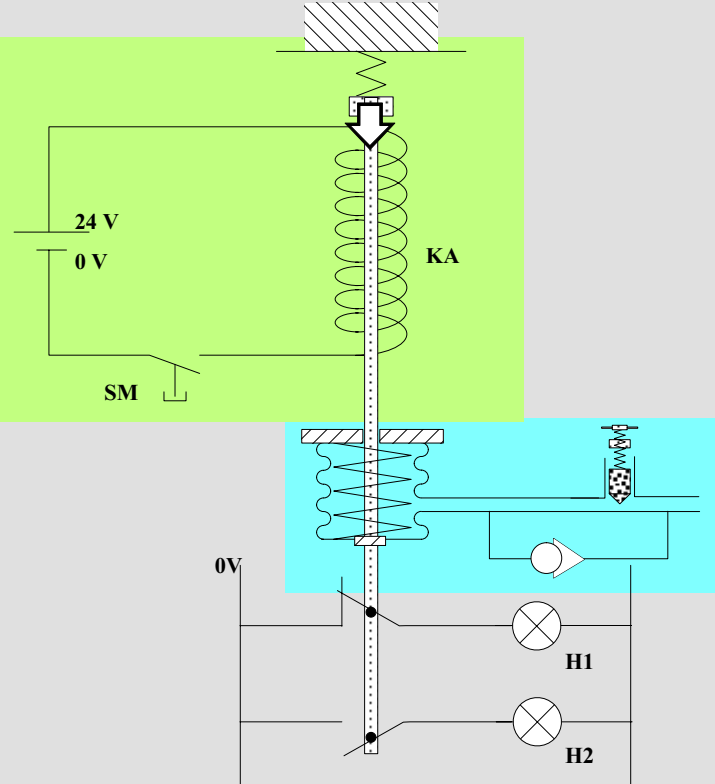

SYMBOLISATION

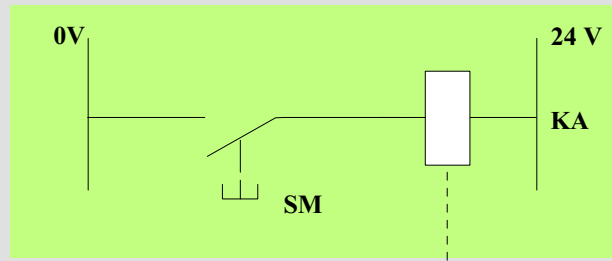

Facultatif

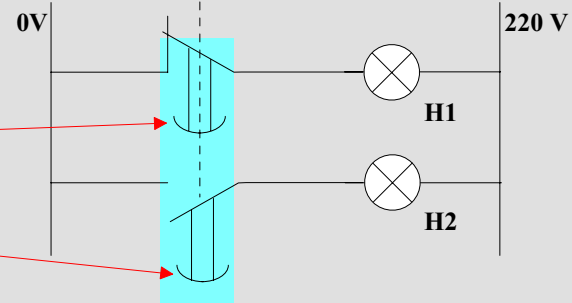

Symbolisation du retard de fermeture ou d'ouverture des contacts

Le parachute retarde la ouverture du contact

Le parachute retarde la fermeture du contact

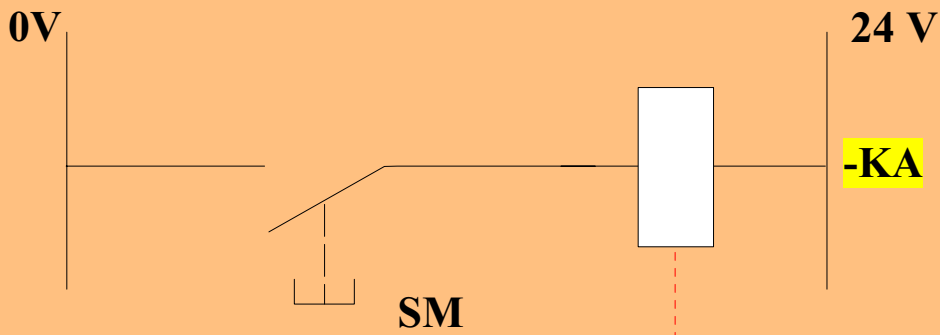

Facultatif

Les contacts ont les mêmes lettres que la bobine

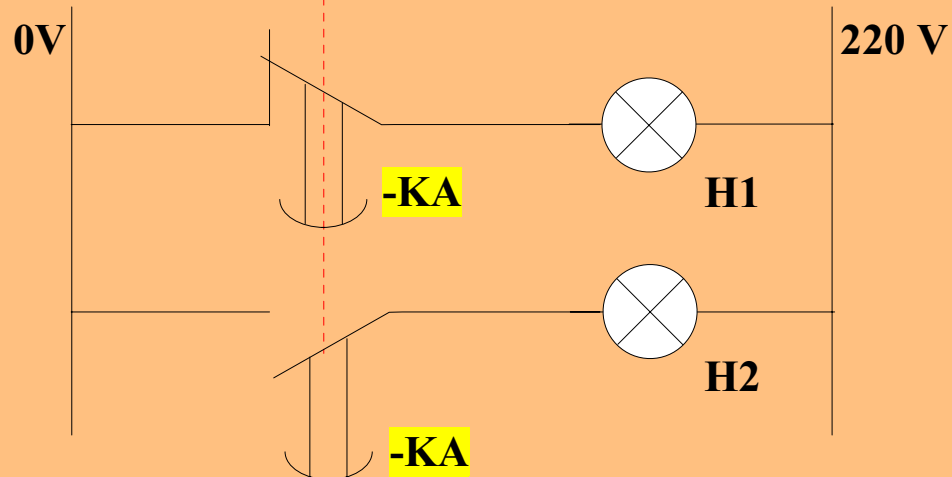

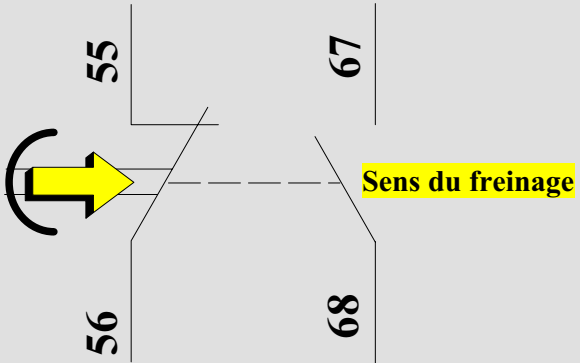

**Contacts repos et travail
tremporisé au travail**

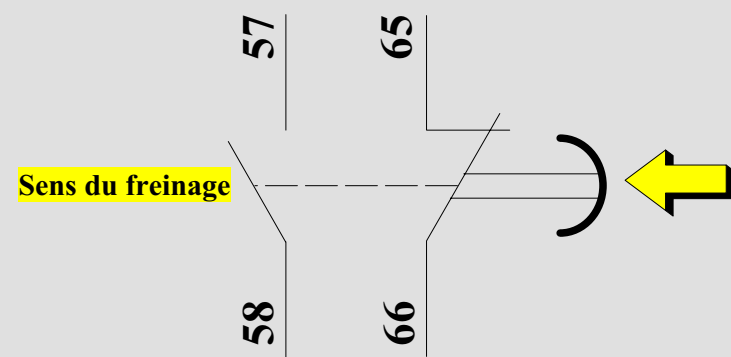

**Contacts repos et travail
temporisés au repos**

FIN