

GRAFCET

1. RECONNAITRE LES POINTS DE VUE:

1.1. Point de vue:

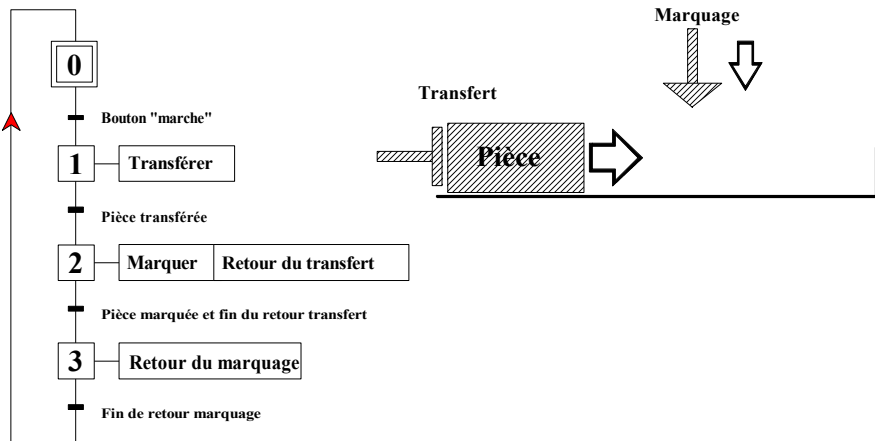

1.2. Point de vue:

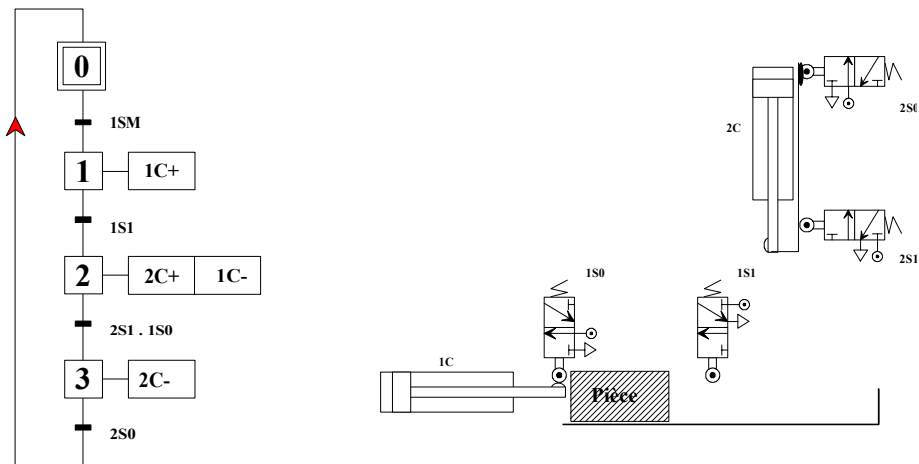

1.3. Point de vue:

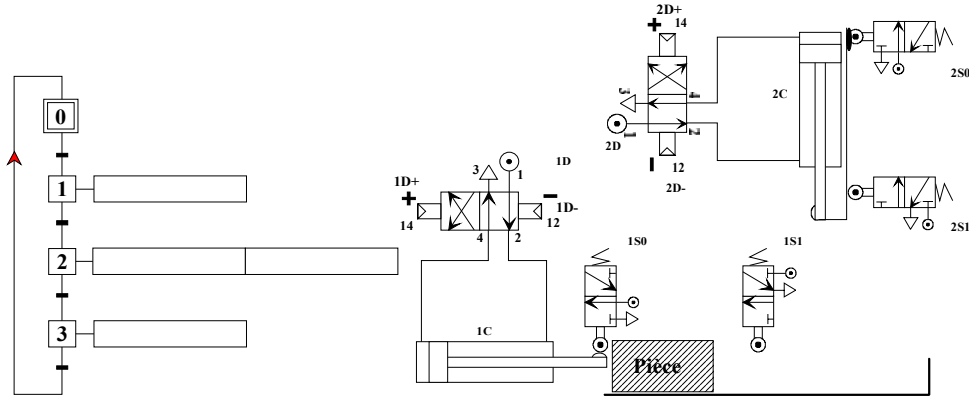

2. CITER LES DIVERS FONCTIONNEMENTS DE CES 2 GRAFCETS

GRAFCET N°1

GRAFCET N°2

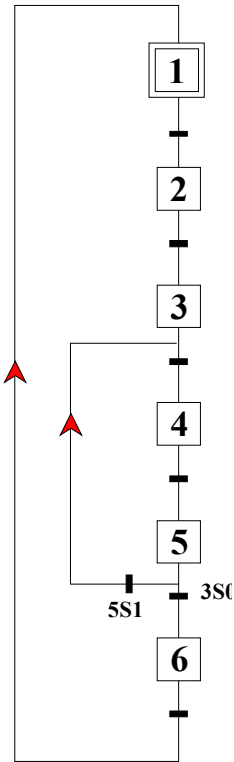
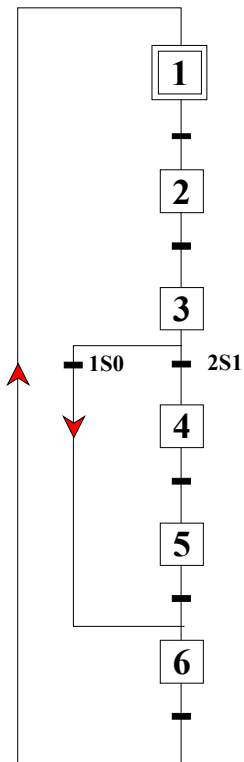

2.1. Grafcet N°1:

étapes:

.....

étapes:

.....

2.2. Grafcet N°2:

étapes:

.....

étapes:

.....

3. DECRIVER LES FONCTIONNEMENTS SUIVANTS:

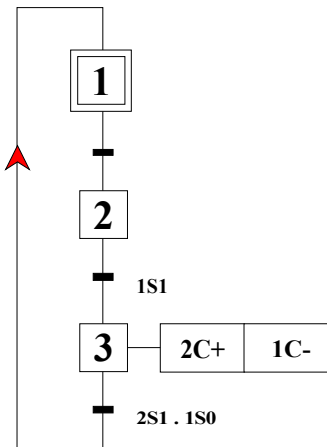

.....

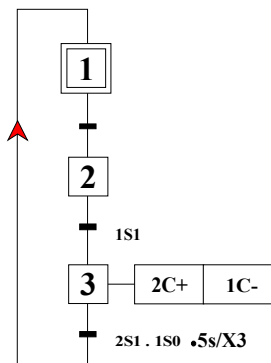

.....

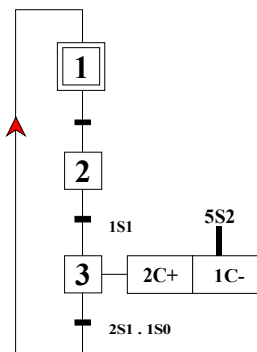

.....

4. DECRIRE LES FONCTIONNEMENTS SUIVANTS ET RAYER LA MAUVAISE REPRESENTATION:

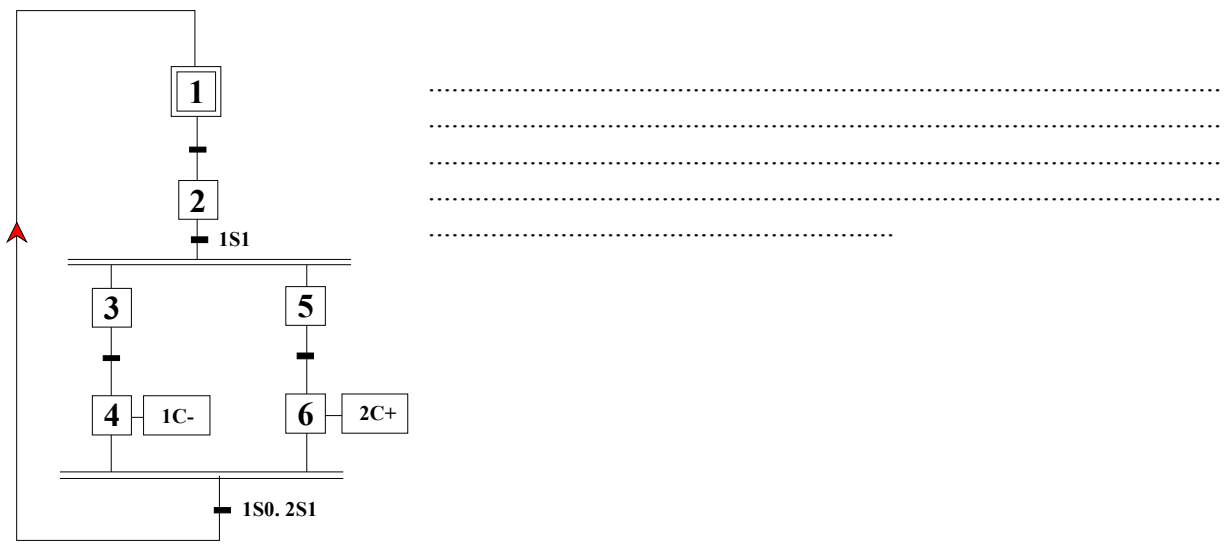
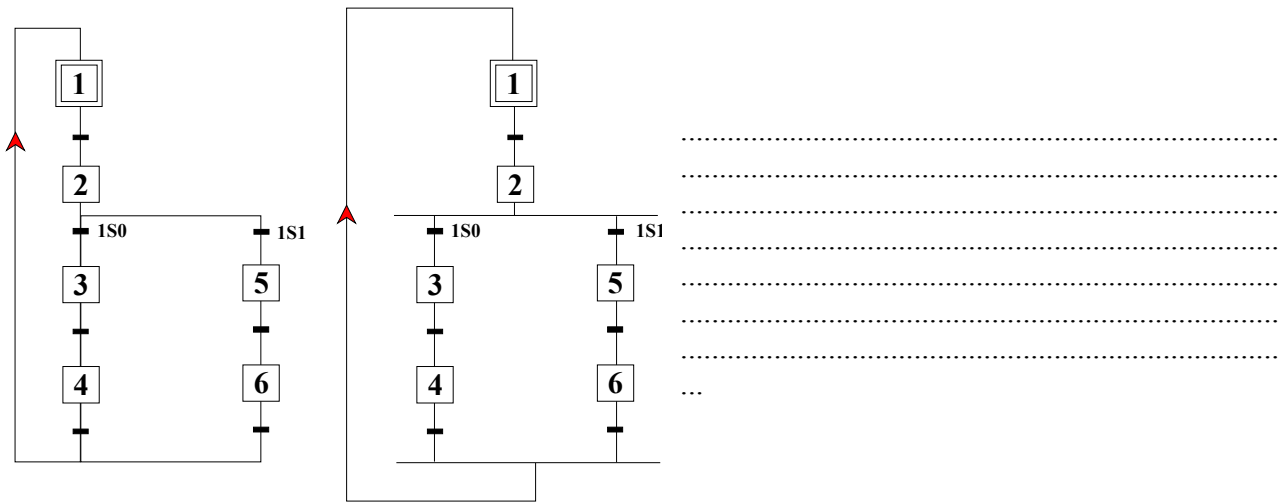

4.1. Pourquoi l'étape initiale à ce cadre pointillé?

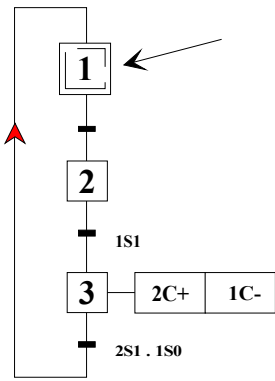

.....

4.2. Que veut dire =1 ?

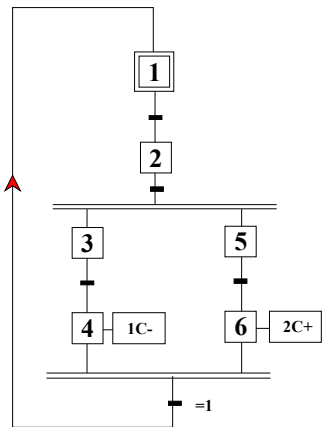

.....

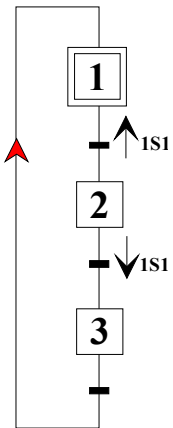

.....

5. QUE SIGNIFIE L'ETAPE EN POINTILLEE?

5.1. Quel est le fonctionnement de ces deux graficets?

GFN

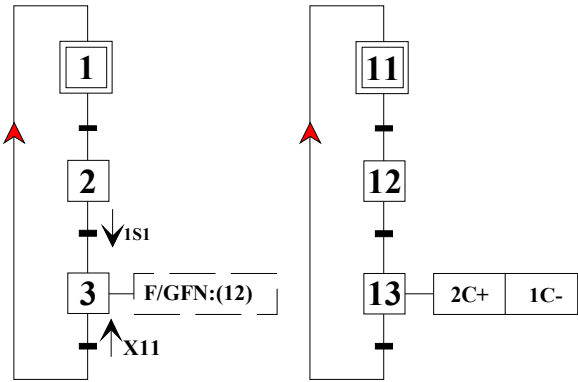

.....

.....

.....

.....

.....

6. DONNER LA SIGNIFICATION DE CE QUE DESIGNENT LES FLECHES:

6.1. Quel est le fonctionnement de ces deux graphets?

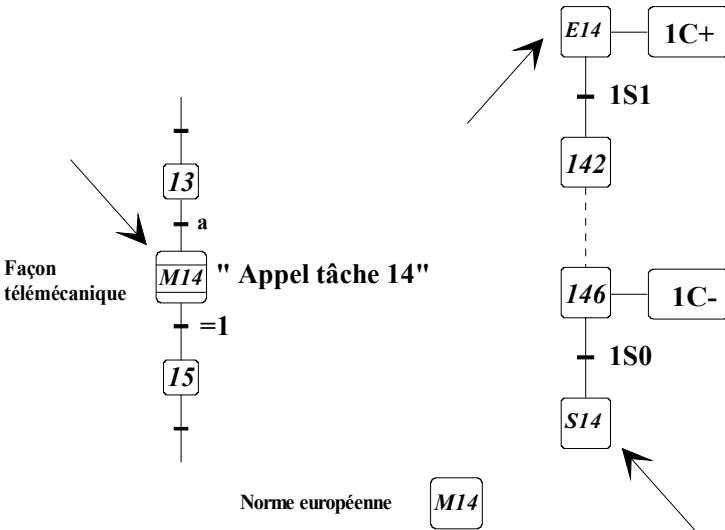

.....

.....

.....

.....

.....

.....

.....

.....

.....

.....

7. BARRER LES ERREURS DE GRAPHISMES

