

Relation câblage / grafcet



"A"
MSP

0 "Attente"

étape initiale

0S4
1 — **1A+**

1S2
2 — **2A-**

2S2
3 — **1A-**

Transition entre l'étape 2 et l'étape 3

Réceptivité

1S1
4 — **2A+**

étape normale

2S1
"A"

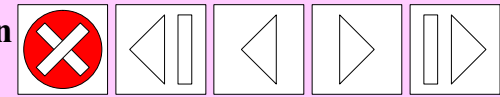

Dans un grafcet point de vue P.O

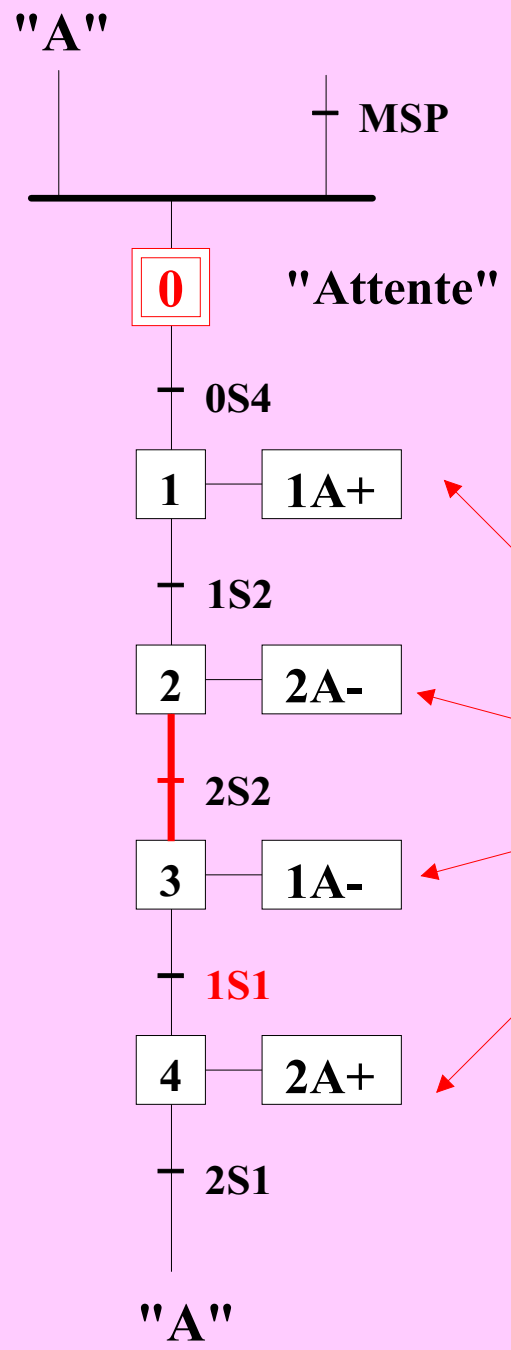

On trouve des actionneurs

**Vérins
Ventouses
etc..**

Dans un grafcet point de vue P.O

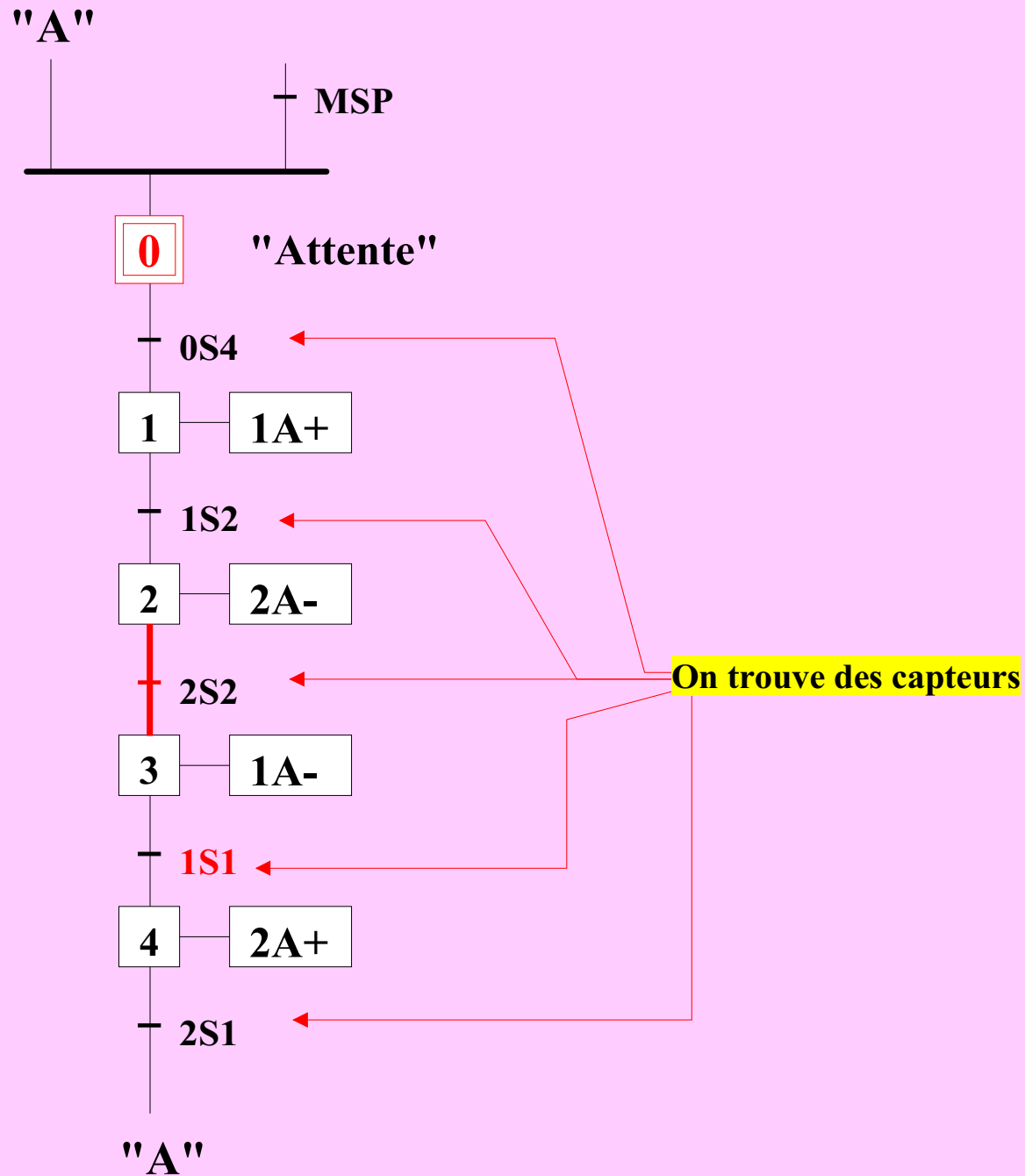

Dans un grafcet point de vue automate

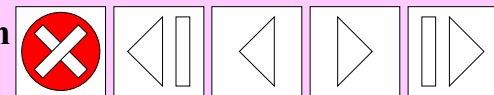
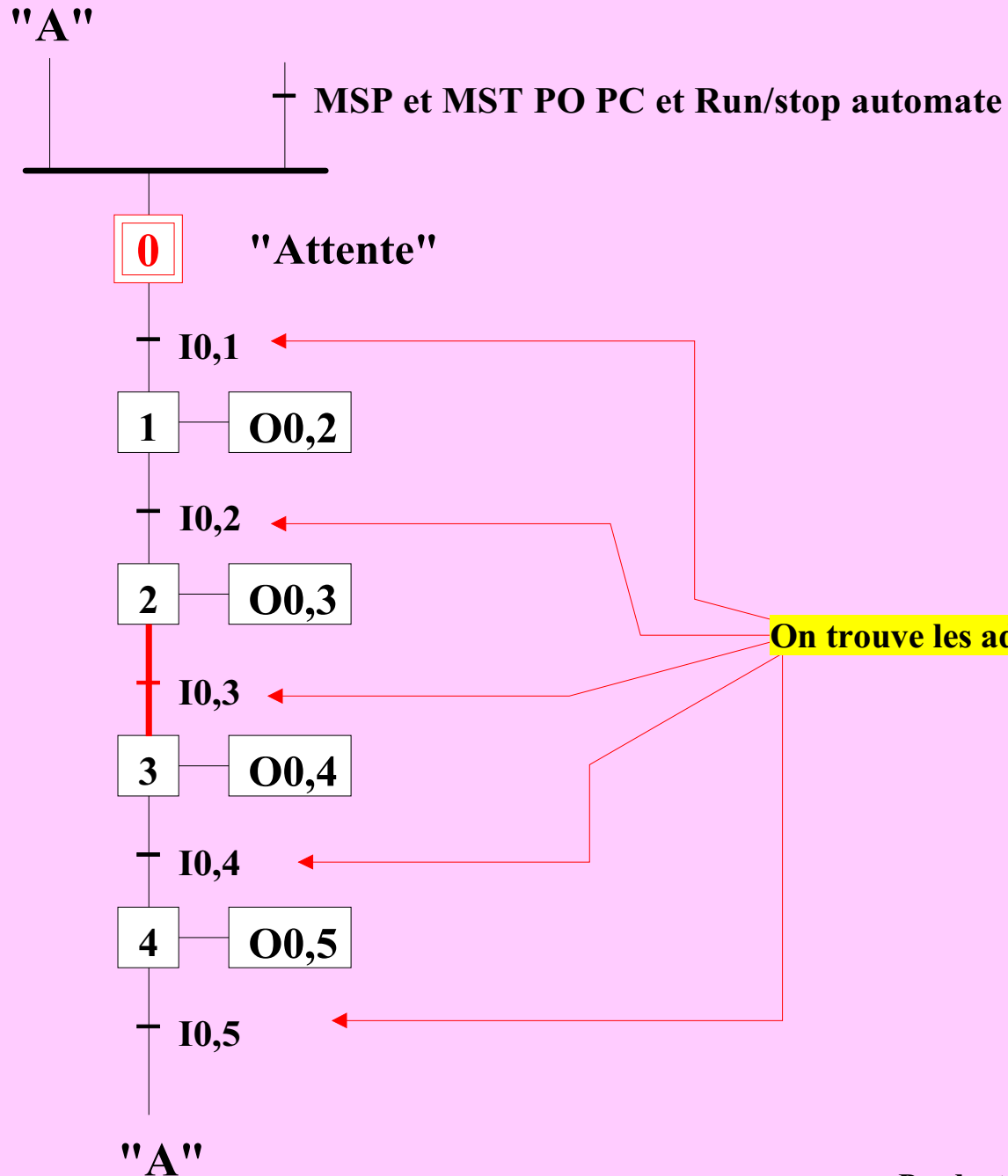

Dans un grafcet point de vue automate

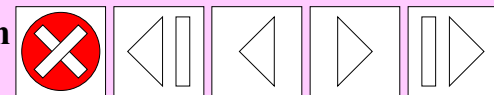
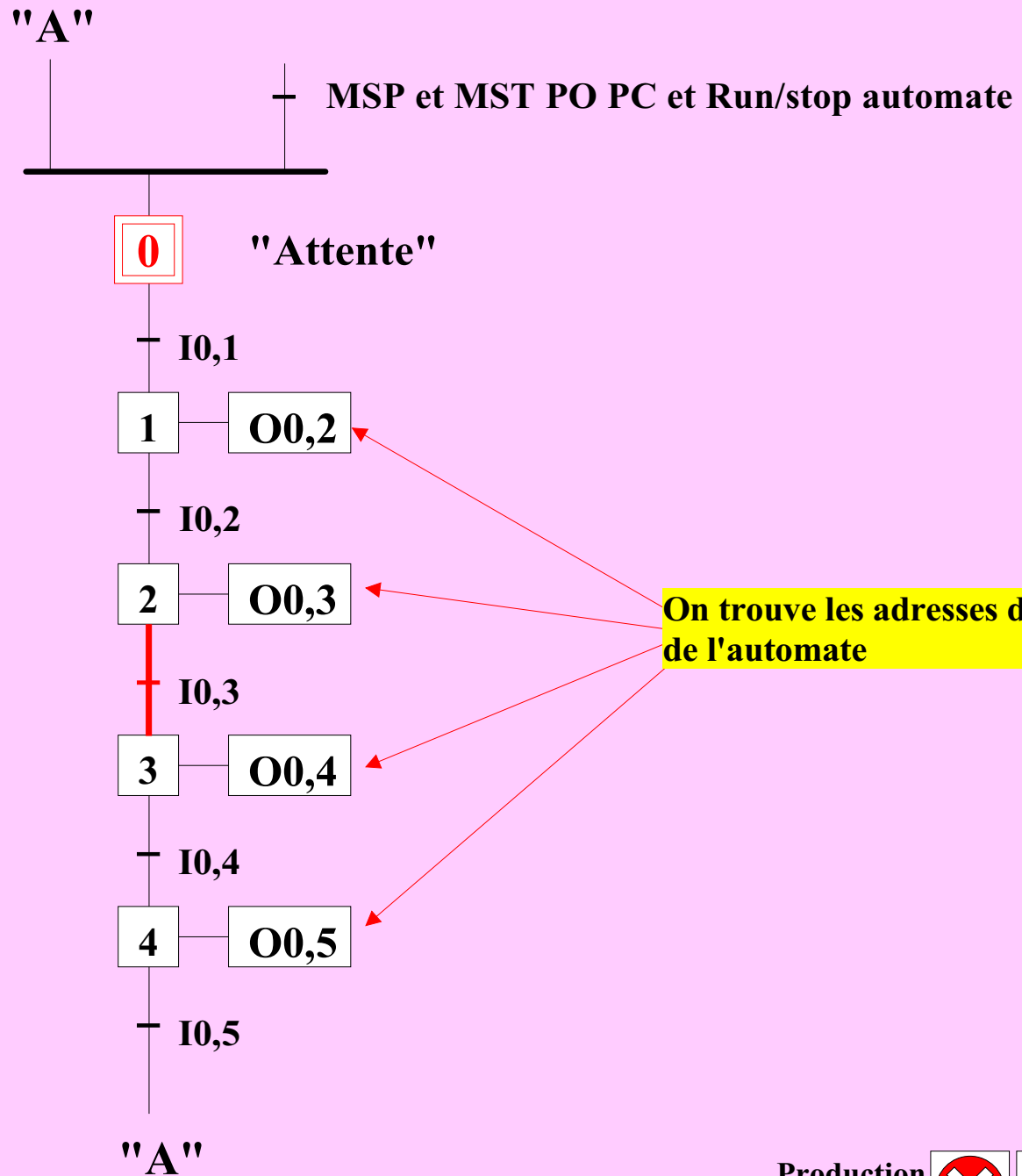

Dans un grafect point de vue automate

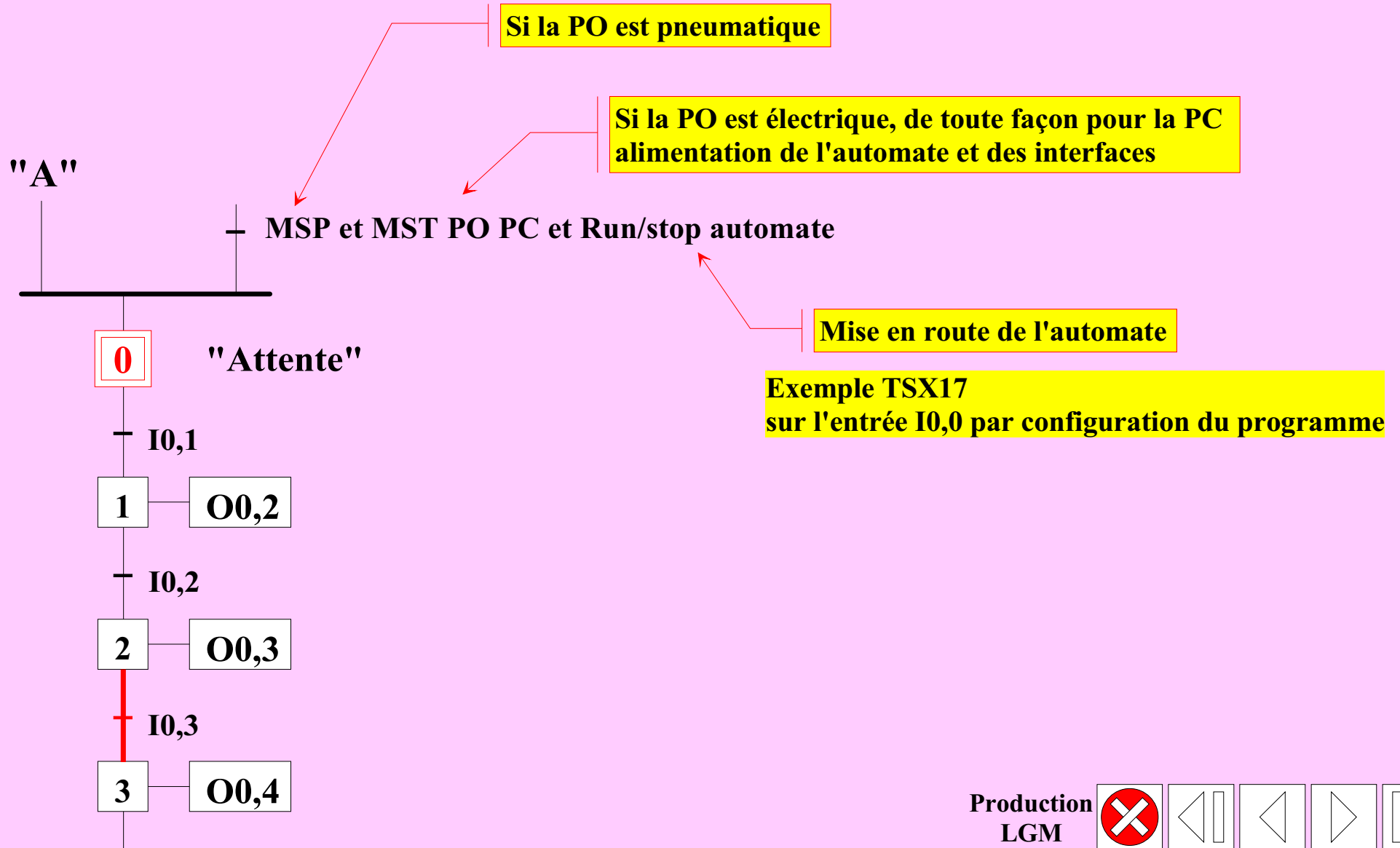

THE END

Echap

Production
LGM

